



Water Activated Tape Dispenser



BP-222

Manual water activated tape dispenser

The BP-222 is a streamlined and lightweight manual water activated tape dispenser. It is ideal for home offices, retailers and low volume shipping environments. The BP-222 is fully portable with no cords or batteries making it a versatile addition to any industry. Water activated tape is fast becoming the preferred method of carton sealing. The BP-222 uses fully recyclable water activated paper tape ensuring your cartons are sealed with the environment in mind.



Efficiency

Fast and efficient tape dispensing for increased productivity.



Enhanced Brand Image

Products that arrive intact and pristine reflect a positive company image



A Superior Seal

Water activated adhesives penetrate into the fibres of the carton

Manual Tape Dispenser

BP-222



Features & Benefits

- Simple operation.
- Easy push tape dispensing
- Portable. Cords, electricity, and battery free.
- Efficient. Tank holds up to one cup (227ml) of water to activate 114 meters.
- Refillable and spill resistant
- Environmentally friendly carton sealing
- Perfect addition for low-volume shipping environments
- Better pack water brushes provide consistent, uniform tap wetting.
- Designed for rolls up to 100m long (for both reinforced and non-reinforced gummed paper tape)

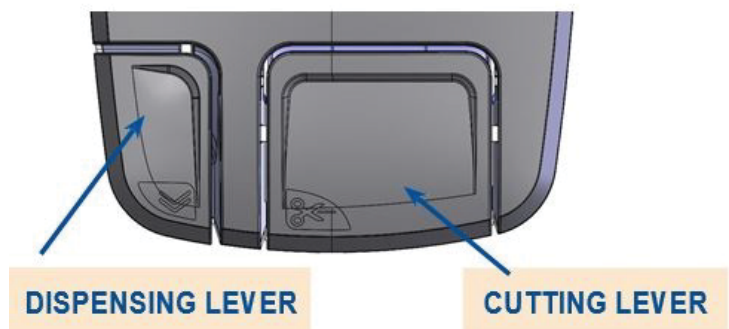
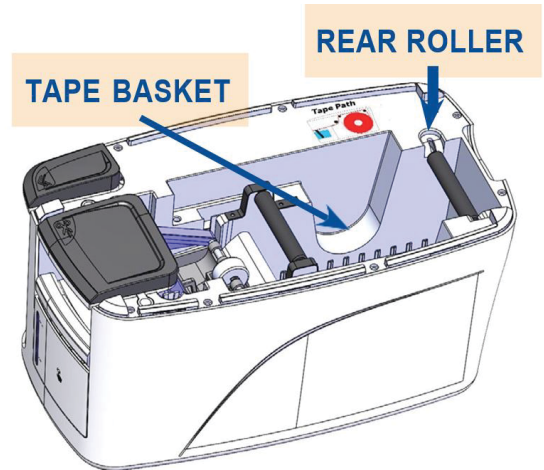

BP-222

